

MATERIAL	TESTA HEAD	Ø mm
B	8	2,4 3,0 4,0 4,8
B	40	

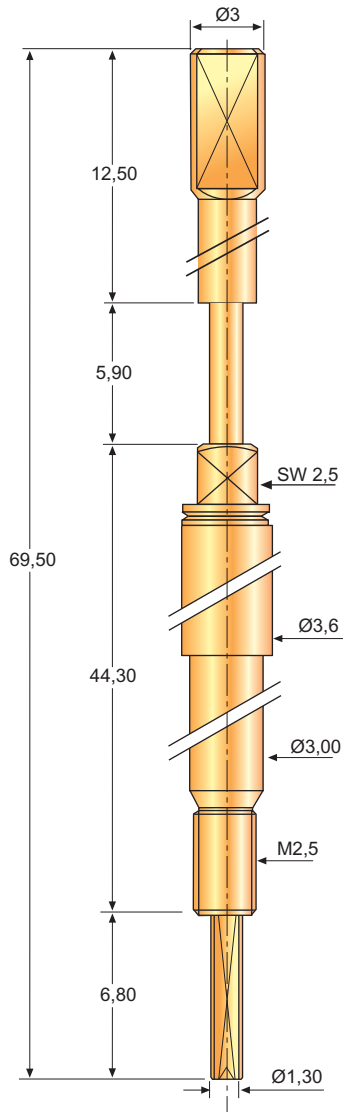

Dati Tecnici

Distanza minima raccomandata :
 Intensità nominale : 8,0 A
 Resistenza tipica : 30 m Ω
 Corsa di lavoro raccomandata:

Technical Data

Recommended Minimum Centers:
 Current Rating: 8,0 A
 Typical Contact Resistance: 30 m Ω
 Recommended Working Travel :

Materiali

Corpo : Ottone dorato
 Molla : Acciaio argentata / dorata
 Pistone : Rame-Berillio, nichel-oro / oro duro

Materials

Barrel : Gold plated
 Spring : Music Wire, silver / gold plated
 Plunger : Becu, hardened 24 Kt gold plated

Informazioni per l'ordine - Order Info:

Serie	Materiale Material	Testa Head	Ø	Forza Molla Spring Force	Galvanica Galvanic
B=Becu	S=Steel				G = gold N = nickel R = rodium
SS=Stainless St.					
SP-34					

R-34

Ricettacolo - Receptacle

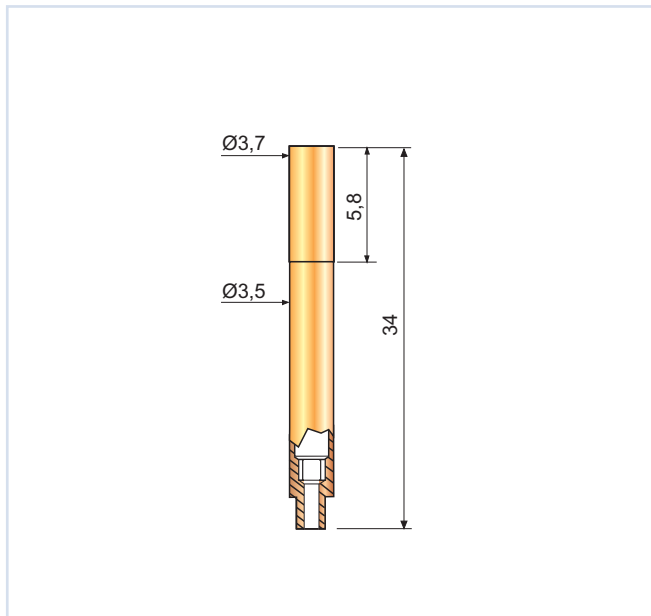

Corsa Max : 5,5 mm.
 Max Travel :

Forza Molla : 300 gr.
 Spring Force :

Prearico : 50 gr.
 Preload :

Opzioni - Options :

Punta di foratura: Drills:

Ø ...



R-34	
------	--

C = Crimp
 S = Saldare
 W = Wire wrap
 WW = With wire